



Standard
Change-Makers, Inc.

STANDARD CHANGE-MAKERS, INC.
3130 N. MITTHOEFFER ROAD
P.O. BOX 36550
INDIANAPOLIS, INDIANA 46236-0550
PH: 317-899-6966
FX: 317-899-6977
www.standardchange.com

UniNote™ DISPENSER MANUAL

Installation & Instruction Manual

FOR FOLLOWING MODELS:
BX1000, BX1000RL,
BCX1000, BCX1000RL,
and other models with UniNote™ Bill Dispenser

Uninote™ Dispenser Service Manual

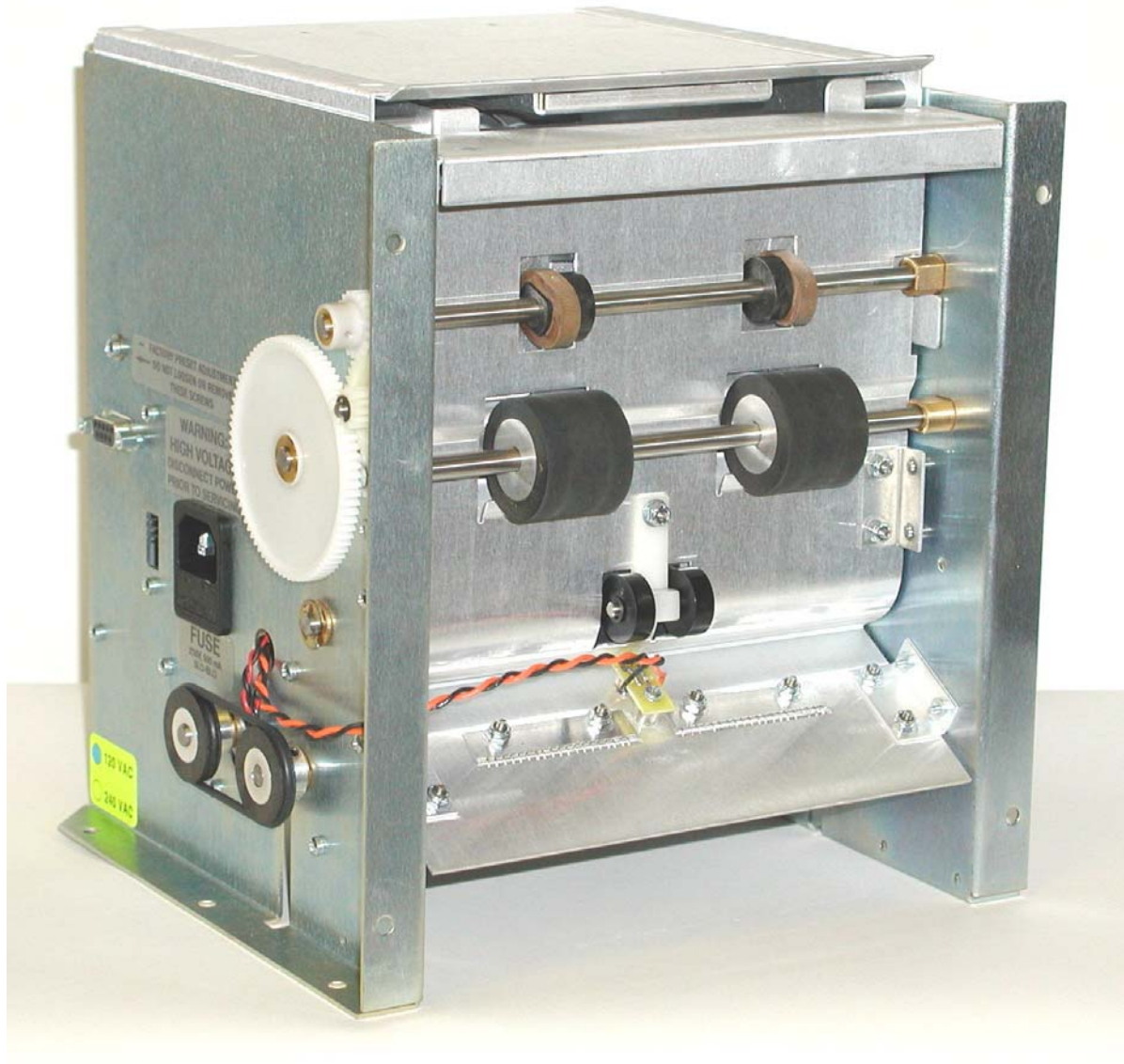

Table of Contents

1. Machine Specifications & Descriptions	1
2. Unpacking, Installation and Repacking.....	2
2.1. Unpacking.....	2
2.2. Installation	2
2.3. Repacking the unit for shipment.....	3
3. Cleaning.....	3
4. Currency Condition and Cassette Loading.....	3
4.1. Currency Condition	3
4.2. Loading the Cassette.....	3
5. Parts Replacement	4
5.1. Mechanical.....	4
5.2. Pulley/Gear/Hub Orientation.....	4
5.3. Pulley/Gear/Roller Set Screws	4
5.4. E- Rings	4
5.5. Major Part and Shaft Locations	4
5.6. Picker Tire Replacement.....	4
5.7. Feed Shaft Assembly Replacement	5
5.8. Stripper Shaft Assembly Replacement.....	5
5.9. Transfer Shaft Assembly Replacement	7
5.10. Front Conveyor Roller Replacement.....	8
5.11. Rear Conveyor Shaft Assembly Replacement.....	8
5.12. Low Note Sensor Assembly Replacement	8
5.13. Document Sensor Assembly Replacement.....	9
5.14. Document LED Assembly Replacement.....	9
5.15. Stacker Sensor Assembly Replacement.....	10
5.16. Stacker LED Assembly Replacement.....	10
5.17. Logic/Power Board Replacement.....	10
6. Electronic Description & Setup.....	11
6.1. Overview.....	11
6.2. Logic/Power Board.....	11
6.3. Communications Interface.....	11

6.4. Document Detect Sensor Voltage Adjustment	16
6.5. Document Sensor/LED Testing	17
6.6. Stacker Sensor/LED Testing.....	17
6.7. Low Note Sensor Testing	18
6.8. Uninote Cable Connections	18
6.9. Uninote Assembly Flow Chart.....	18
7. Troubleshooting Guide	19
7.1. No Power	19
7.2. Machine Will Not Start.....	19
7.3. Jamming.....	19
7.4. Frequent Double/Chain Errors.....	19
7.5. Communications Errors	19
8. List of Recommended Spare Parts.....	20
9. List of Recommended Tools.....	21
10. Illustrated Parts Breakdown.....	22

Revision	Date	Description
-	12/98	Initial Release
A	7/99	Updated Parts List To –01A Version
B	10/99	Updated Figures
C	03/01	Updated Stripper Adjustment
D	03/05	Important: Cleaning rollers note added

Table of Figures

Figure 1 Mounting Holes and Overall Dimensions.....	22
Figure 2 Left Side View	23
Figure 3 Cutaway View	25
Figure 4 Right Side View	27
Figure 5 Stripper Friction Adjustment.....	29
Figure 6 Logic/Power Board Assembly	31
Figure 7 Connection Diagram	32
Figure 8 Assembly Flow Chart.....	33
Figure 9 Schematic Diagram	34
Figure 10 Picker Shaft Assembly	35
Figure 11 Feed Shaft Assembly.....	36
Figure 12 Stripper Shaft Assembly.....	37
Figure 13 Transfer Shaft Assembly	38
Figure 14 Front Conveyor Shaft Assembly.....	39
Figure 15 Rear Conveyor Shaft Assembly	40
Figure 16 Test Circuit.....	40
Figure 17 Sample RS-232 Command Sequence.....	41
Figure 18 Sensor/LED Locations	43

1. Machine Specifications & Descriptions

FEATURES	SPECIFICATIONS
Capabilities	World currency, notes whose length and height do not exceed cassette dimensions
Durability	Average to heavy-duty operation
Size, including cassette(HWD)	9.0 in. x 8.5 in. x 8.0 in. (229 mm. x 216 mm. X 203 mm.)
Weight, including cassette	10 lbs. (4.5 kg.); shipping 13 lbs. (5.9 kg.)
Dispensing Speed	1.3 U.S. notes per second
Currency Fitness	“Average/Good Street” to “Well Broken Brick”
Cassette Capability	750 used/1000 new U.S. notes
Escrow Capability	Customer configuration determines capacity
Feed Technique	Friction: positive drive system
Error Detection	Double and chain
Error Handling	Before it is dispensed, each bill fed is checked to verify that it is only one note and not a multiple (double) and not overlapped by another bill such that no gap exists between bills (chain). If an error is detected, only the bill or bills sensed to be doubles or chains are rejected into an escrow receptacle below the unit and another note is fed.
Connection	RS-232 interface and Low level polar pulse mode (+5VDC)
Electrical	120/240 50/60 Hz
Operating Environment	Temperature: 50° F to 95° F (10° C to 35° C) Humidity: 30% to 80% RH
Storage Environment	Temperature: -4° F to 140° F (-20° C to 60° C) Humidity: 30% to 80% RH
Warranty	90 days parts and labor
Payout	The feed path is perpendicular to the long dimension of bills. The bills are dispensed into a customer-supplied receptacle. Bills must not be able to be manually fed by turning any customer accessible mechanism to dispense a bill.

2. Unpacking, Installation and Repacking

2.1. Unpacking

Save the carton and all packing material, in the event the Uninote requires service.

2.2. Installation

A. Mounting

Figure 1 shows the mounting holes for the Uninote. Sufficient room should be left above and behind the Uninote to allow for the convenient installation/removal of the cassette. There should be sufficient room on the left side (viewed from the front) of the Uninote to allow for the installation/removal of the electrical connection and communication interface cable. The right side should be kept free of anything that might interfere with the pulleys and belts located there. The area under the Uninote is addressed in “Dispense Output” and “Reject Output”.

B. Dispense Output

The enclosure must provide a receptacle for the dispensed notes. It should be located far enough away from the Uninote that the first notes dispensed do not prevent succeeding notes from clearing the output area of the Uninote. The receptacle should also be sufficiently large that notes that are skewed exiting the Uninote do not block succeeding notes from clearing the output area. The maximum number of notes dispensed should be limited to fit easily in the receptacle. The receptacle area should be segregated from the reject area by a barrier to prevent rejected notes from inadvertently entering the output area.

C. Reject Output

The enclosure must provide a receptacle for notes that may be rejected when error conditions are detected. It should be large enough and deep enough to allow rejected notes to clear the reject area and remain clear of the area. While the number of rejects cannot be estimated, as it will vary with note condition, the rejected notes must not get close to the reject area after they have cleared.

D. Before connecting the Uninote to a power supply, verify that the operating voltage of the unit and the line voltage present are the same. The Uninote can be supplied for either 120 or 240VAC 50-60Hz. The unit’s operating voltage configuration can be confirmed by checking the serial number label, which is located on the upper corner of the right side plate (see Figure 4). A voltage label can also be found on the lower corner of the left side plate. (See Figure 2).

E. The unit is supplied with an RS-232 pulse mode communication interface. Detailed information regarding interface signal connections is provided in Section 6.3. Interface connections are made through the DB9 connection on the left side of the unit.

F. The Uninote is now ready for operation.

2.3. Repacking the unit for shipment

- A. Place the unit in the plastic bag.
- B. Attach top and bottom protective inserts.
- C. Fold down the carton flaps and seal with tape.

3. Cleaning

Periodic cleaning will optimize performance and prolong the life of the unit. Customer cleaning should include the following: picker tires, feed rollers (Important- clean feed rollers thoroughly), stripper rollers and front conveyor rollers.

Clean these friction surfaces by manually turning the mechanism via the 60-tooth timing pulley, which is located on the right side of the unit (see Figure 4) or use the Cleaning Mode switch, which is accessed by removing the cassette. These surfaces should be cleaned at least once a month. Frequent usage will require more frequent cleaning. Use isopropyl alcohol wipes (P/N 41408). A vacuum cleaner can be used to remove excessive dust and dirt from the unit.

IMPORTANT: When cleaning rollers with isopropyl alcohol wipes, use lightly. Do not soak the rollers. If rollers become soaked, do not run the unit. Allow rollers to dry completely. Immediate damage to the rollers will occur if the unit is run while the rollers are wet.

4. Currency Condition and Cassette Loading

4.1. Currency Condition

Optimum performance of the Uninote is achieved if the note condition is limited to ATM fit or average to good teller grade currency. Torn, taped or badly curled bills should be culled out. Broken brick mixed with circulated notes will feed but increases the possibility of stoppages. The use of broken brick alone or in significant quantities is not recommended.

4.2. Loading the Cassette

Care should be taken when loading the cassette to ensure notes are neatly stacked. Straighten bent corners and separate notes obviously interlocked. Tap the cassette gently to ensure that the stack is settled on the bottom.

CAUTION!

Do not run the Uninote feed mechanism without documents for an extended period of time. Damage may result.

5. Parts Replacement

CAUTION!

- **Disconnect power prior to servicing.**
- **If any parts are dropped into the Uninote, STOP and retrieve the items. The misplaced items will be needed when the unit is reassembled or damage may result.**

5.1. *Mechanical*

Detailed descriptions or standard workshop procedures, safety principles and service operations are not included in this manual. It is important to note that this manual contains some warnings and cautions against some specific service methods that could cause personal injury to service personnel or could damage equipment or render it unsafe. Anyone using service procedures or tools, whether or not recommended by G&D America, Inc., must be satisfied that neither personal safety or equipment safety will be jeopardized by the service method or tools selected.

5.2. *Pulley/Gear/Hub Orientation*

When pulleys, gears or rollers are removed from any shaft the orientation of the hub and shaft flat should be noted for later reinstallation.

5.3. *Pulley/Gear/Roller Set Screws*

When a setscrew is used to secure a pulley, gear or roller on a shaft, the shaft has a flat to position or locate the part. When setscrews are tightened, first ensure that the tip of the setscrew will encounter the flat of the shaft before tightening. A slight rocking motion of the component as the setscrew is tightened will aid in positioning the setscrew perpendicular to the flat. If the setscrew is tightened against the round surface of a shaft, later removal may be difficult. Do not over tighten any setscrew.

5.4. *E- Rings*

E-Rings are used to secure shafts and rollers in place. They can easily be removed and reinstalled. Use a small flat blade screwdriver or small needle nose pliers for removal.

5.5. *Major Part and Shaft Locations*

Figure 3 shows a cutaway view of the Uninote. This view can be used to identify major parts and shafts.

5.6. *Picker Tire Replacement*

(See Figure 10)

- Remove the e-ring from the right end of the picker shaft.
- Loosen but do not remove the two (2) picker hub set screws.
- Slide the shaft to the left. Gear remains attached to shaft. Bearing will also slide out.
- Slide picker hub/tire off the right end of the shaft.

- E. Remove the worn picker tires and install new picker tires.
- F. Reassemble in reverse order.
NOTE: Picker hubs face inward.
- G. Center the picker hubs in the feed plate cutout and tighten the setscrews.
CAUTION: Over tightening could crack or damage the hub.

5.7. Feed Shaft Assembly Replacement

(See Figure 11)

- A. Remove the gear from the left end of the stripper shaft (see Figure 12).
- B. Remove the combination gear from the left side plate (see Figure 2).
- C. Remove the gear from the left end of the feed shaft. Note the special screw and external lock washer used to retain the gear. The screw must be tight at reassembly.
- D. Loosen the motor mounting screws to ease timing belt tension.
- E. Remove the e-ring from the right side of the feed shaft.
- F. Slide the timing pulley off the end of the shaft.
IMPORTANT: When reassembling, the timing pulley flange faces outward.
- G. Remove the left and right bearings.
- H. Slide the shaft assembly to the right so that the left end of the shaft goes through the bearing hole. The shaft assembly can now be removed.
- I. Reassemble in reverse order. Stripper shaft endplay has to be set at .010/.015 in. (.25/.38 mm). See Figure 12. Feed shaft endplay is set. No adjustment is required.
- J. Check/adjust stripper tension per Section 5.8.I.

5.8. Stripper Shaft Assembly Replacement and Adjustment

(See Figure 12)

- A. Remove the cassette.
- B. Remove the four (4) upper hopper shelf mounting screws. Loosen the two (2) lower hopper shelf mounting screws. Pivot the hopper shelf back 90° to an upright position. Retighten the lower screws. This will hold the hopper shelf in position and allow access to the stripper shaft assembly.
- C. Remove the e-ring from the right side of the stripper shaft.
- D. Remove the gear from the left side of the stripper shaft.
- E. Remove the left and right bearing block mounting screws.
- F. Move bearing blocks and shaft assembly back until bearing flange is free of the side plate.
- G. Slide the shaft assembly to the left so that the right end of the shaft goes through the side plate bearing hole. The shaft assembly can now be removed.

- H. Reassemble in reverse order. This shaft requires an endplay setting of .010/.015 in. (.25/.38 mm). Leave the hopper shelf in the upright position. This will allow access to the stripper adjustment mechanism.
- I. Adjust the stripper friction (see Figure 5).

Manual (Pull) Method

1. Feed and stripper wheels must be cleaned prior to adjustment. Use isopropyl alcohol wipes (P/N 41408).
2. Loosen the right and left locking nuts and turn the adjusting screws so that the feed and stripper wheels are not touching.
3. Manually feed the stripper adjustment note between the left stripper and feed roller. Be careful not to feed the note so far as to have it become engaged by the acceleration section (between the transfer and idler rollers).
4. Turn the left stripper adjustment screw while slowly pulling the test note out of the pinch. Continue adjusting until the note just starts to drag. Do not tighten the locking nut.
5. Repeat steps 3 and 4 on the right stripper/feed roller pair.
6. Manually feed the stripper adjustment note (Pull Force Gauge - see Figure 5) between the left stripper and feed roller, being careful not to feed the note too far.
7. Turn the left stripper adjustment screw while slowly pulling the note out of the pinch with the Pull Force Gauge. This should be a steady pull at the same rate that the note is coming out. Continue adjusting until a 12 oz. (340 gr.) force is required to pull the note out of the stripper mechanism. Do not tighten the locking nut.
8. Repeat steps 6 and 7 on the right stripper/feed roller pair.
9. Verify left and right setting.
10. While holding the left stripper adjustment screw securely, tighten the locking nuts.
11. Lock the right stripper adjustment screw as described above.
12. Recheck the left and right settings to ensure that the pull force on both stripper/feed roller pairs is balanced and that they are adjusted within 1 oz. (28 gr) of each other.
Important: If at this point the settings do not meet the above criteria, minor compensations can be made by loosening one of the locking nuts and re-adjusting.

Run (Switch) Method

1. Feed and stripper wheels must be cleaned prior to adjustment. Use isopropyl alcohol wipes (P/N 41408).
2. Loosen the right and left locking nuts and turn the adjusting screws so that the feed and stripper wheels are not touching.
3. Manually feed the stripper adjustment note between the left stripper and feed roller. Be careful not to feed the note so far as to have it become engaged by the acceleration section (between the transfer and idler rollers).

4. Turn the left stripper adjustment screw while slowly pulling the test note out of the pinch. Continue adjusting until the note just starts to drag. Do not tighten the locking nut.
5. Repeat steps 3 and 4 on the right stripper/feed roller pair.
6. Manually feed the stripper adjustment note (Pull Force Gauge - see Figure 5) between the left stripper and feed roller, being careful not to feed the note too far.
7. Depress and hold the cleaning button. With the machine running, turn the left stripper adjustment screw until a reading of 6 - 8 oz. (170 - 220 gr.) is achieved. Do not tighten the locking nuts.
8. Repeat steps 6 and 7 on the right stripper/feed roller pair.
9. Verify left and right setting.
10. While holding the left stripper adjustment screw securely, tighten the locking nuts.
11. Lock the right stripper adjustment screw as described above.
12. Recheck the left and right settings to ensure that the pull force on both stripper/feed roller pairs is balanced and that they are adjusted within 1 oz. (28 gr) of each other.
Important: If at this point the settings do not meet the above criteria, minor compensations can be made by loosening one of the locking nuts and re-adjusting.
- J. Loosen the two (2) lower hopper shelf mounting screws and rotate hopper shelf to closed position.
- K. Replace the four (4) upper hopper shelf mounting screws and tighten the two (2) lower mounting screws.

5.9. Transfer Shaft Assembly Replacement

(See Figure 13)

- A. Remove the cassette.
- B. Remove the four (4) upper hopper shelf mounting screws. Loosen the two (2) lower hopper shelf mounting screws. Pivot the hopper shelf back 90° to an upright position. Retighten the lower screws. This will hold the hopper shelf in position and allow access to the transfer shaft assembly.
- C. Loosen the motor mounting screws to ease timing belt tension.
- D. Remove the e-ring from the right side of the transfer shaft.
- E. Slide the timing pulley off the end of the shaft.
IMPORTANT: When reassembling, the timing pulley flange faces inward.
- F. Remove the e-ring from the left side of the transfer shaft.
- G. Remove the left and right bearings.
- H. Slide the shaft assembly to the right so the left end of the shaft goes through the bearing hole. The shaft assembly can now be removed.
- I. Reassemble in reverse order.

5.10. Front Conveyor Roller Replacement

(See Figure 14)

- A. Remove the cassette.
- B. Turn the machine over so that the hopper shelf is facing down.
- C. Remove the conveyor drive o-ring from the left side of the unit (see Figure 2).
- D. Remove the o-ring pulley and bearing from the left side of the front conveyor shaft.
NOTE: When reassembling, do not over tighten the o-ring pulley set screw. This could crack or damage the hub.
- E. Remove the timing pulley and bearing from the right end of the front conveyor shaft.
- F. Remove the front conveyor shaft assembly by sliding it up and back in the slots provided.
- G. Remove and replace old rollers by removing either outer e-ring.
- H. Reassemble in reverse order. Front conveyor shaft goes in with the short end of the shaft facing the left side. Check that LED assembly wires are dressed properly and are not rubbing against the rollers. This shaft requires an endplay setting of .010/.015 in. (.25/.38 mm).

5.11. Rear Conveyor Shaft Assembly Replacement

(See Figure 15)

- A. Remove the conveyor drive o-ring from the left side of the unit (see Figure 2).
- B. Remove the o-ring pulley and bearing from the left side of the rear conveyor shaft.
NOTE: When reassembling, do not over tighten the o-ring pulley set screw. This could crack or damage the hub.
- C. Remove the e-ring and bearing from the right side of the rear conveyor shaft.
- D. Turn the machine over so that the hopper shelf is facing down.
- E. Remove the old shaft assembly by sliding it up and forward in the slots provided.
- F. Replace the rear conveyor shaft assembly.
- G. Reassemble in reverse order. Rear conveyor shaft goes in with the short end of the shaft facing right. This shaft requires an endplay setting of .010/.015 in. (.25/.38 mm).

5.12. Low Note Sensor Assembly Replacement

(See Figure 18)

- A. Remove the cassette.
- B. Remove the four (4) upper hopper shelf mounting screws.
- C. Loosen the two (2) lower hopper shelf mounting screws and rotate hopper shelf to upright position (90°). Retighten the two (2) lower screws. This will hold the hopper shelf in position and allow access to the low note sensor assembly.
- D. Unplug the low note sensor assembly at the PC board.

- E. Gently pry the cable clamp up and remove the wires.
NOTE: If necessary, replace the cable clamp when reassembling the unit.
- F. Remove the two (2) lock nuts that are used to secure the low note sensor assembly to the hopper shelf.
- G. The old low note sensor assembly can now be removed.
- H. Install the new low note sensor assembly and reassemble the unit in reverse order.

5.13. Document Sensor Assembly Replacement

(See Figure 18)

- A. Remove the cassette.
- B. Remove the four (4) upper hopper shelf mounting screws.
- C. Loosen the two (2) lower hopper shelf mounting screws and rotate hopper shelf to upright position (90°). Retighten the two (2) lower screws. This will hold the hopper shelf in position and allow access to the document sensor assembly.
- D. Unplug the document sensor assembly at the PC board.
- E. Remove the screw that is used to secure the document sensor assembly to the conveyor plate.
- F. The old document sensor assembly can now be removed.
- G. Install the new document sensor assembly and reassemble the unit in reverse order.
- H. Readjust document sensor sensitivity per Section 6.4.

5.14. Document LED Assembly Replacement

(See Figure 18)

- A. Remove the hopper shelf.
- B. Unplug the document LED assembly at the PC board. Pass the wire and plug through the upper wire pass hole in the left side plate (see Figure 2). Turn the machine over so that the top surface is facing down. Pass the wire and plug through the lower wire pass hole.
- C. Remove the front conveyor shaft assembly. See Section 5.10.
- D. Gently pry the cable clamps up and remove the wires.
NOTE: If necessary, replace cable clamps when reassembling the unit.
- E. Remove the screw that is used to secure the document LED assembly to the stacker plate.
- F. The old document LED assembly can now be removed.
- G. Install the new document LED assembly. Check that wires are dressed properly and are not pinched. Also check that the wires are not rubbing against the front conveyor rollers. Make sure that the new assembly is seated in the plastic holder and that the plastic holder is seated in the plate. Board circuitry must clear the front conveyor shaft spring.

- H. Reassemble the unit in reverse order.
- I. Readjust document sensor sensitivity per Section 6.4.

5.15. Stacker Sensor Assembly Replacement

(See Figure 18)

- A. Remove the cassette.
- B. Remove the four (4) upper hopper shelf mounting screws.
- C. Loosen the two (2) lower hopper shelf mounting screws and rotate hopper shelf to upright position (90°). Retighten the two (2) lower screws. This will hold the hopper shelf in position and allow access to the PC board connector.
- D. Unplug the stacker sensor assembly at the PC board.
- E. Remove the screw that is used to secure the stacker sensor assembly to the feed plate.
- F. The old stacker sensor assembly can now be removed.
- G. Install the new stacker sensor assembly and reassemble the unit in reverse order.

5.16. Stacker LED Assembly Replacement

(See Figure 18)

- A. Remove the hopper shelf.
- B. Unplug the stacker LED assembly at the PC board. Pass the wire and plug through the upper wire pass hole in the left side plate (see Figure 2). Turn the machine over so that the top surface is facing down. Pass the wire and plug through the lower wire pass hole.
- C. Remove the front conveyor shaft assembly. See Section 5.10.
- D. Gently pry the cable clamps up and remove the wires.
NOTE: If necessary, replace cable clamps when reassembling the unit.
- E. Remove the screw that is used to secure the stacker LED assembly to the stacker plate.
- F. The old stacker LED assembly can now be removed.
- G. Install the new stacker LED assembly. Check that wires are dressed properly and are not pinched. Also check that the wires are not rubbing against the front conveyor rollers.
- H. Reassemble the unit in reverse order.

5.17. Logic/Power Board Replacement

(See Figure 3)

- A. Remove the cassette.
- B. Remove the hopper shelf assembly. Unplug the low note sensor at the PC board.

- C. Note the location of the various connections to the PC board. Unplug each connection, marking each one if necessary (see Figure 7).
- D. Remove the four (4) screws that are used to secure the PC board to the bracket.
- E. The old PC board can now be removed.
- F. Install the new PC board.
- G. Reassemble the unit in reverse order.
- H. Readjust document sensor sensitivity per Section 6.4.

6. Electronic Description & Setup

6.1. Overview

The voltages required by the Uninote electronics are low; however, line voltage is present at the power connector and transformer when the unit is plugged in.

EXERCISE CAUTION WHEN SERVICING REQUIRES POWERED-UP OPERATION AND THESE AREAS ARE EXPOSED.

6.2. Logic/Power Board

The logic/power board is mounted at the rear of the unit. Removing the hopper shelf allows access to it. Figure 6 is a view of the PC board assembly with test point information. Figure 7 shows the PC board connection diagram.

The logic/power board provides the unit's control and interface functions as well as providing all DC voltages required by the Uninote. The major components include a microprocessor (U1), a motor controller (U2), an RS-232 interface (U3) and a +5 volt regulator (VR1). A complete schematic is shown in Figure 9.

The Uninote can be operated from a computer through an RS-232 connection or by a specifically timed pulse train (see Section 6.3). A test mode has also been provided for dispensing one note at a time and resetting error conditions. The circuit for using the single note test mode is shown in Figure 16. See caution concerning operating the Uninote without notes (Section 4.2).

The Uninote will not respond to an RS-232, pulse train or test mode dispense if any of the following conditions exists:

- A. The Low Bin Sensor detects there are less than 20-40 documents in the cassette.
- B. The stacker Sensor is blocked.

NOTE: If the Uninote is in an otherwise ready state when an RS-232 or pulse dispense command is received, the dispense will start when the stacker obstruction is removed. A reset command can be used to cancel a pending dispense.

- C. An error condition (such as bin empty, excess errors, etc.) from the previous dispense had not been cleared by sending an "X" command or by a pulse mode reset.
- D. Too many notes were requested. The Uninote does not accept a request for more than 20 notes.

6.3. Communications Interface

The Uninote may be connected to a controller via an RS-232 or pulse mode interface. The specifications for these interfaces are listed below.

RS-232 CONTROL

The RS-232 interface uses the EIA Standard RS-232C Interface Between Data Terminal Equipment and Data Communication Equipment Employing Serial Binary Data Interchange.

RS-232 Interface Specification:

Mode of Operation	Asynchronous, Half Duplex	
Baud Rate	2400	
Start Bits	1	
Stop Bits	2	
Parity	None	
Character Code	7 bits (ASCII)	
SIGNAL:	Receiver	Transmitter
True (Active Low)	-3 to -25 volts	-12 volts
False (Active High)	+3 to +25 volts	+12 volts

RS-232 Commands:

All multi-character commands (example: command to dispense 10 notes is *A10R*) must be sent such that the spacing between successive characters is less than 100ms. The preferred method is to send all sequences as strings. Before dispensing, request status to find out if the Uninote is ready to dispense; i.e., send S, receive GQ for ready. Only the S and Q commands are recognized when the Uninote is running. The Uninote must be in a dispense complete/ready error state to respond to any other command. See Figure 17 for a typical command sequence.

DISPENSE			
COMMAND	ASCII	HEX	DEFINITION OR PRECONDITION
Dispense String Prefix	A	41	Informs Uninote dispense is being initiated.
Number of Notes	0	30	These characters represent the number of notes to be dispensed. NOTE: One or two digits (leading zeros permissible). Maximum dispense is 20 notes. A higher number will not be accepted
	1	31	
	2	32	
	3	33	
	4	34	
	5	35	
	6	36	
	7	37	
	8	38	
9	39		
Dispense String Terminator	R	52	Used to end sequence.

Example: A10R is the command to dispense 10 notes.

QUIT/CLEAR REJECT			
COMMAND	ASCII	HEX	DEFINITION OR PRECONDITION
Quit	Q	51	Stops Uninote if running.
Clear Error	X	58	Clears errors and allows further operation. Not needed for bin low and stacker blocked errors, which are cleared by correcting the condition.
Master Reset	RA	52 41	Clears processor and UART. Reinitializes program (like turning unit off and on).
Reset Feed	RF	52 46	Rejects one note, and does a clear error (same as X). An error condition that exists after a feed reset occurred during the reset operation.

INTERROGATE			
COMMAND	ASCII	HEX	DEFINITION OR PRECONDITION
Return Count	VA	56 41	Calls for number of notes dispensed. Two-digit number in ASCII characters with leading 0 (30H) for one-digit responses. This number is available until the next dispense or master reset. It is not cleared by a clear error.
Return Reject	VR	56 52	Calls for number of notes rejected. Two-digit number in ASCII characters with leading 0 (30H) for one-digit responses. This number is available until the next dispense or master reset. It is not cleared by a clear error.
Status Request	S	53	Calls for the status of the unit

RESPONSES TO STATUS REQUEST		
RESPONSE TO S		DEFINITION OR PRECONDITION
ASCII	HEX	
GQ	47 51	Ready to dispense, or dispense complete with no errors.
H	48	Stacker blocked while Uninote is attempting to dispense. Feeding resumes when stacker is cleared (status will return to "Z"). Sending a "Q" at this point will terminate the dispense in process.
Z	5A	Uninote is running.
E S1 through S9	45 S1 through S9	Dispense error.
That is, E followed by nine ID characters designated: S1 S2 S3 S4 S5 S6 S7 S8 S9. Each character is a 1 or a 0. 1(31H) = Error; 0(30H) = OK.		Unit will not run until a clear error, master clear or reset feed is received. Sending a pulse mode reset will also clear this error condition.
S1 = 1.....*		Stacker Blocked- If a dispense string is received while the Uninote is in this condition, the unit will start dispensing when the stacker is cleared.
S2 = 1.....***		Low Note- Number of notes goes below approx. 30 to 50. S2 is cleared when the cassette is reloaded.
The following are cleared by the Clear Error command. A new dispense cannot start unless all are 0.		
S3 = 1.....*		Bin Empty- no notes feed in three tries.
S4 = 1.....*		Jam- Notes under document sensor for an excessive period of time.
S5 = 1.....*		Note fed, but does not go into stacker. This is usually caused by hardware failure.
S6 = 1.....*		Extra note is fed into stacker. This is usually caused by hardware failure.
S7 = 1.....**		5 or 6 width errors (chain or short) in one dispense.
S8 = 1.....**		5 or 6 double errors in one dispense.
S9 = 1.....*		7 errors in one dispense.
* Stops dispense at this point. ** Warning only; does not stop dispense. *** A low note condition will not stop a dispense in process. New dispenses will not be permitted until more notes are added.		
E111111111	45H & 9 31H's	Pulse line error. A request for more than 20 notes was received on the pulse control line.

# COMMAND AND RESPONSE			
COMMAND	ASCII	HEX	DEFINITION OR PRECONDITION
Return software version	#R	23 52	Calls for software version in unit.
<i>Response</i>	Nn	3x 3x	Two-digit number in ASCII characters
Return extended status	#S	23 53	Calls for specific reason why notes were rejected.
<i>Response</i> (one-digit ASCII character)	@	40	No error
	C	43	Width error (chain or short)
	D	44	Double
	G	47	Double and chain

RS-232 Control Signals:

	Uninote DB9	PC Serial Connector DB25	DB9	
TXD, Transmit Data	2----->	3	2	RXD, Receive Data
RXD, Receive Data	3<-----	2	3	TXD, Transfer Data
SG, Signal Ground	5----->	7	5	SG, Signal Ground
RTS, Request to Send	8----->	5	8	CTS, Clear to Send

When the RTS line is true, active high, it is OK to send.

PULSE MODE CONTROL

The Uninote can be controlled by the pulse mode interface. The controller must send pulse string comprised of 60 ms (low) pulses with 300 ms (high) spaces between. A space longer than 330 ms is considered to be the pulse train terminator and further pulses will not be accepted until the Uninote stops running. The pulse train can not be longer than 20 pulses. If more than 20 pulses are received, the Uninote will stop dispensing on the 21st pulse and go into a pulse line error condition. The number of notes dispensed may be less than 20.

The Busy line will be high when the Uninote is running.

The error conditions bin empty, jam, excess errors, pulse line error, and note sequence errors cause the Uninote to stop dispensing and the /Enable line to go high. Further dispenses are not possible until the error condition is reset.

Applying a low pulse on the Pulse line for more than 200 ms will reset stop error conditions (pulse line reset).

The stacker blocked and low note errors will prevent the Uninote from starting a new dispense and cause the /Enable line to go high. A pulse line reset can not clear these errors. However a new pulse train will be accepted under a stacker blocked condition. The dispense will begin when the stacker is cleared.

Pulse Mode Interface Specification:

<u>PULSE CONTROL</u>	UNINOTE:	CONTROLLER:
ENABLE (Active Low) = Operate	Output- Open collector	Input- Receiver pull-up to +5 volts (1k)
BUSY (Active High) = Running	Output- Open collector	Input- Receiver pull-up to +5 volts (1k)
PULSE (Active Low)	Input- Pull up to +5 volts (1k)	Output- Dispense notes with: Pulses: +5 v to 0 v/gnd 60 ms, ±6 ms Spacing: 300 ms, ±30 ms

Pulse Mode Control Signals:

	UNINOTE	CONTROLER
<u>Pulse Control</u>	DB9	
Busy Out	1----->	Busy In
Enable Out	6----->	Enable In
Pulse In	9<-----	Pulse Out

SINGLE NOTE DISPENSE TEST MODE

The Uninote can be operated in a single note dispense mode for test proposes. The signals required to operate in this mode are described below.

TEST	Shorting the PULSE and BUSY pins together for >200 ms will dispense 1 note.
RESET	An error can be cleared at any time by shorting PULSE to ground for >200 ms.

Figure 16 shows a schematic diagram of the single note dispense/reset test circuit.

6.4. Document Detect Sensor Voltage Adjustment

(See Figure 6)

- A. Locate Document Detect Sensor voltage adjustment test points.
- B. Short pin 2 (GND) and 3 (CAL).
- C. Connect positive voltmeter lead to pin 1 (TP1).
- D. Connect negative voltmeter lead to pin 2 (GND).
- E. Apply power to Uninote.
- F. Manually feed a test note made from 20-lb. white bond paper under Document Detect Sensor.

G. Adjust resistor R14 until voltmeter reads 2.5VDC.

NOTE: If the voltage varies as the test note is moved back and forth under the sensor, make the adjustment at a point on the test note where the voltage is an average between high and low reading.

H. Remove meter probes and shorting jumper.

6.5. Document Sensor/LED Testing

(See Figure 6)

A. Connect positive voltmeter lead to J2-1

B. Connect negative voltmeter lead to J2-2.

C. A reading of approximately 1.5 VDC indicates an illuminated Document Detect LED.

D. Perform Document Detect Sensor Voltage Adjustment Procedure (Section 6.4).

E. If the Document Detect Sensor Voltage Adjustment Procedure could be implemented as outlined, proceed to step G.

F. A voltmeter reading of less than 0.5 VDC would indicate a defective Document Detect Sensor. A higher reading would indicate a defective, misaligned, or improperly seated Sensor or LED.

G. With the voltmeter connected as outlined in the Document Detect Sensor Voltage Adjustment procedure, the readings should be as follows:

Clear feed path	> 3.0 VDC.
Sensor blocked	< 1.2 VDC.

H. Readings falling outside the above specifications would indicate a defective, misaligned, or improperly seated Sensor or LED.

6.6. Stacker Sensor/LED Testing

(See Figure 6)

A. Connect positive voltmeter lead to J2-5.

B. Connect negative voltmeter lead to J2-6.

C. A reading of approximately 1.5 VDC indicates an illuminated Stacker LED.

D. Connect positive voltmeter lead to J2-12.

E. Connect negative voltmeter lead to J2-11.

F. With the voltmeter connected as outlined above, the readings should be as follows:

Sensor clear	> 3.0 VDC.
Sensor blocked	< 0.8 VDC.

NOTE: J2-7 -8 and J5-9-10 must have jumper blocks installed unless additional sensors have been implemented in the terminal.

6.7. Low Note Sensor Testing

(See Figure 6)

- A. Connect positive voltmeter lead to J2-13.
- B. Connect negative voltmeter lead to J2-14.
- C. With the voltmeter connected as outlined above, the readings should be as follows:

Sensor clear 5.0 VDC.

Magnet over sensor 0 VDC.

6.8. Uninote Cable Connections

Figure 7 shows the cable connections used in the Uninote. The schematic diagram is shown in Figure 9.

6.9. Uninote Assembly Flow Chart

Figure 8 shows the various subassemblies used to build up the Uninote. This chart may be useful to identify parts that are not commonly replaced.

7. Troubleshooting Guide

7.1. No Power

- A. Check that wall outlet has power and/or unit is connected to wall outlet.
- B. Verify that line voltage matches unit's voltage connection.
- C. Disconnect power and check fuse.

7.2. Machine Will Not Start

- A. Disconnect power and rotate the hopper shelf to an upright position (90°). Verify that the motor connector is plugged in at the PC board. Inspect the connectors at the transformer. Verify that they are seated properly.
- B. Verify that a low note condition does not exist and that the low note sensor is functioning properly (see Section 6.7).
- C. Verify that the stacker sensor is not blocked and that the stacker sensor is functioning properly (see Section 6.6.)
- D. Verify that the document sensor is not blocked and that the document sensor is functioning properly (see Section 6.5).

7.3. Jamming

- A. Verify notes are of acceptable quality.
- B. Check/adjust stripper tension.
- C. Verify there are no obstructions in the feed path.
- D. Check/clean rollers if necessary.
- E. Verify document sensor voltage is correct per Section 6.4.

7.4. Frequent Double/Chain Errors

- A. Verify notes are of acceptable quality.
- B. Check/adjust stripper tension.
- C. Check/clean rollers if necessary.
- D. Verify document sensor voltage setting is correct per Section 6.4.

7.5. Communications Errors

- A. Verify RS-232 interface is plugged in.
- B. Visually check for loose connections.
- C. Disconnect power and rotate the hopper shelf to an upright position (90°). Verify that the RS-232 connector is plugged in at the PC board.
- D. Verify that commands are being sent from the terminal to the Uninote.

8. List of Recommended Spare Parts

Listed below are the recommended parts to initially stock to service units. The number of items and their quantities depend on several factors such as the unit's frequency of use, the allowable time the unit can be out of service, and the spare parts replacement cycle.

PART NUMBER	DESCRIPTION	QTY PER UNIT	QTY PER 50 UNITS
4B41747	O-Ring Belt	1	3
4B41889	Fuse	1	6
4B41970	Timing Belt (185 T.)	1	3
4B61040	Rear Conveyor Shaft Assembly	1	2
4B51825	Picker Tire	2	4
4B52023	Anti-Static Brush	2	2
4B52103	Front Conveyor Roll	2	2
4B61042	PC Board Assembly	1	2
4B61045	Feed Shaft Assembly	1	2
4B60879	Document LED Assembly	1	2
4B60881	Document Sensor Assembly	1	2
4B60882	Low Note Sensor Assembly	1	1
4B61046	Timing Pulley assembly (60 T.)	1	1
4B61044	Transfer Shaft Assembly	1	2
4B61048	Timing Pulley Assembly (40 T.)	1	1
4B60905	Pressure Roll Assembly	2	2
4B42008	Motor Assembly	1	1
4B61010	Stacker Sensor Assembly	1	2
4B61011	Stacker LED Assembly	1	2
4B61043	Stripper Shaft Assembly	1	2

In addition to the items listed, G&D America, Inc. recommends that a sufficient quantity of standard hardware (screws, e-rings, etc.) be kept on hand.

9. List of Recommended Tools

Listed below are the tools required to service the Uninote:

Screwdriver, Flat Blade, ¼ inch

Screwdriver, Phillips, #1

Screwdrivers, Phillips, #2

Hex Driver Set

Nut Driver Set

Wrench, Open End, 11/32 in.

Pliers, Mini Needle Nose

Pliers, Mini Diagonal Flush Cut

Feeler Gauge, .001 to .026 inches

Digital Volt Meter

1/4 in E-Ring Insertion Tool-Waldes Truarc E-015-.025

5/32 in. E-Ring Insertion Tool- Waldes Truarc E-025-.025

.010/.015 in. Shaft Endplay Gauge

Mechanical Push/Pull Gauge 0-32 oz (0-1000 gr.) Chatillion #516-1000 or equivalent

10. Illustrated Parts Breakdown

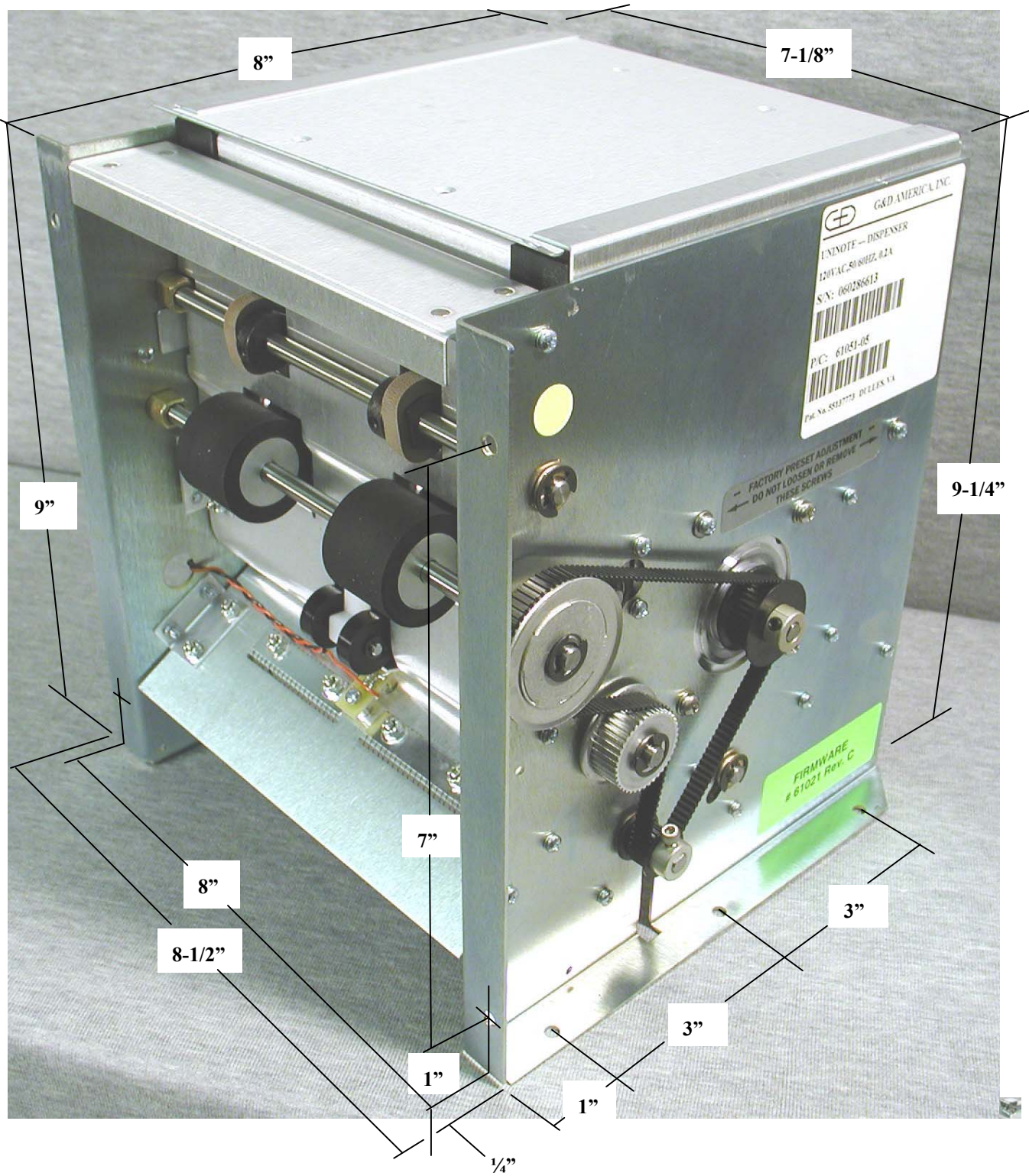

Figure 1 – Mounting Holes and Overall Dimensions

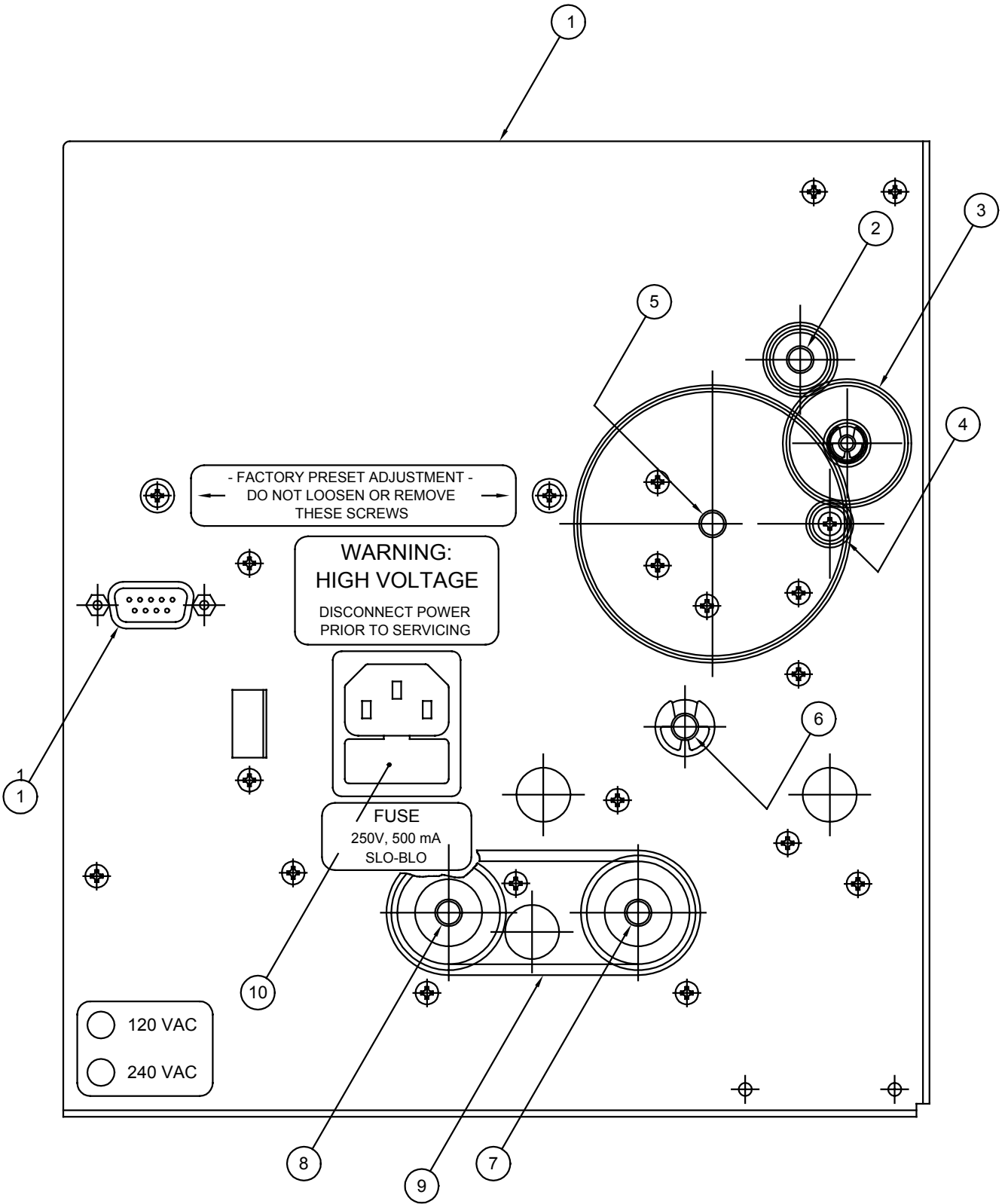

Figure 2 Left Side View

ITEM	QUANTITY	DESCRIPTION	PART NUMBER
1	1	Left Side Plate	Reference
2	1	Picker Shaft Assembly	Reference
3	1	Combination Gear (12/36 Tooth)	52100
4	1	Feed Shaft Assembly	61045
5	1	Stripper Shaft Assembly	61043
6	1	Transfer Shaft Assembly	61044
7	1	Front Conveyor Shaft Assembly	Reference
8	1	Rear Conveyor Shaft Assembly	61040
9	1	O-Ring Belt	41747
10	1	Fuse	41889
11	1	RS-232 Cable Assembly	Reference

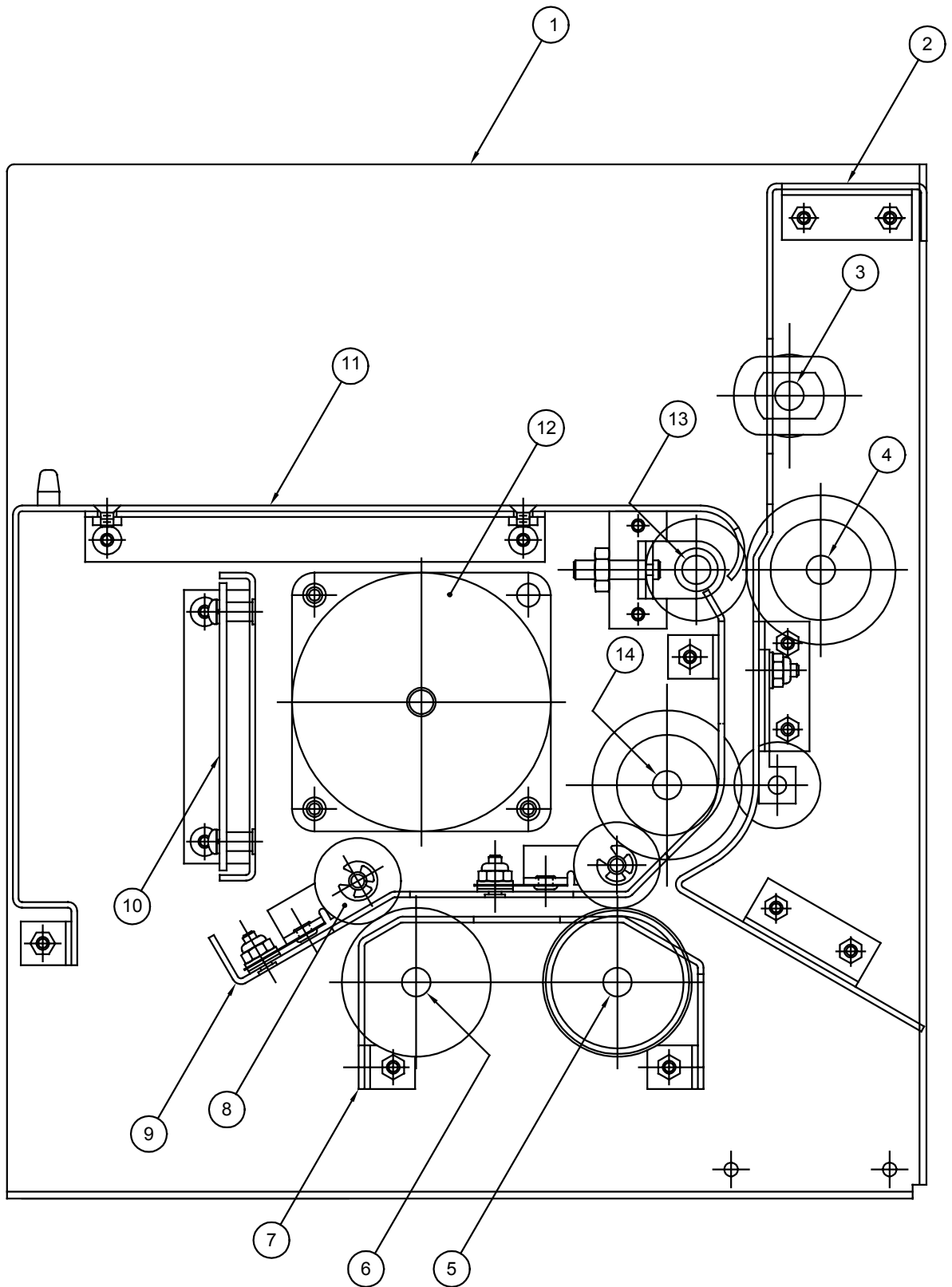

Figure 3 Cutaway View

ITEM	QUANTITY	DESCRIPTION	PART NUMBER
1	1	Right Side Plate	Reference
2	1	Feed Plate Assembly	Reference
3	1	Picker Shaft Assembly	Reference
4	1	Feed Shaft Assembly	61045
5	1	Front Conveyor Shaft Assembly	Reference
6	1	Stacker Plate Assembly	Reference
7	1	Rear Conveyor Shaft Assembly	61040
8	2	Pressure Roll Assembly	60905
9	1	Conveyor Plate Assembly	Reference
10	1	PC Board Assembly	61042
11	1	Hopper Shelf Assembly	Reference
12	1	Motor Assembly	42008
13	1	Stripper Shaft Assembly	61043
14	1	Transfer Shaft Assembly	61044

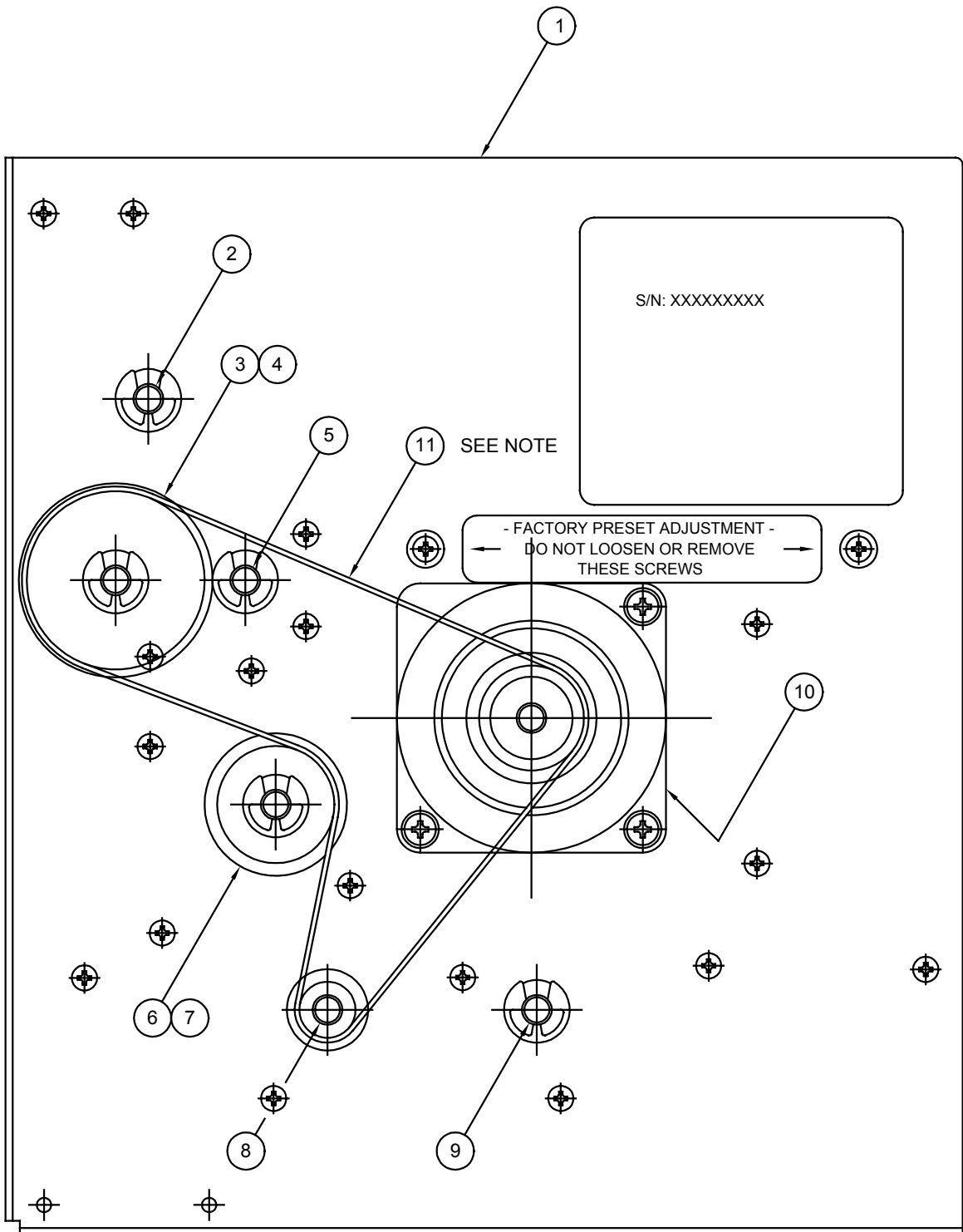

Figure 4 Right Side View

ITEM	QUANTITY	DESCRIPTION	PART NUMBER
1	1	Right Side Plate	Reference
2	1	Picker Shaft Assembly	Reference
3	1	Timing Pulley Assembly (60 Tooth)	61046
4	1	Feed Shaft Assembly	61045
5	1	Stripper Shaft Assembly	61043
6	1	Transfer Shaft Assembly	61044
7	1	Timing Pulley Assembly (40 Tooth)	61048
8	1	Front Conveyor Shaft Assembly	Reference
9	1	Rear Conveyor Shaft Assembly	61040
10	1	Motor Assembly	42008
11	1	Timing Belt (185 Tooth)	41970

NOTE:

Early versions of the Uninote were supplied with a longer (212 tooth) timing belt and idler. On these units, eliminate the idler and use the 185 tooth timing belt, which is a direct replacement.

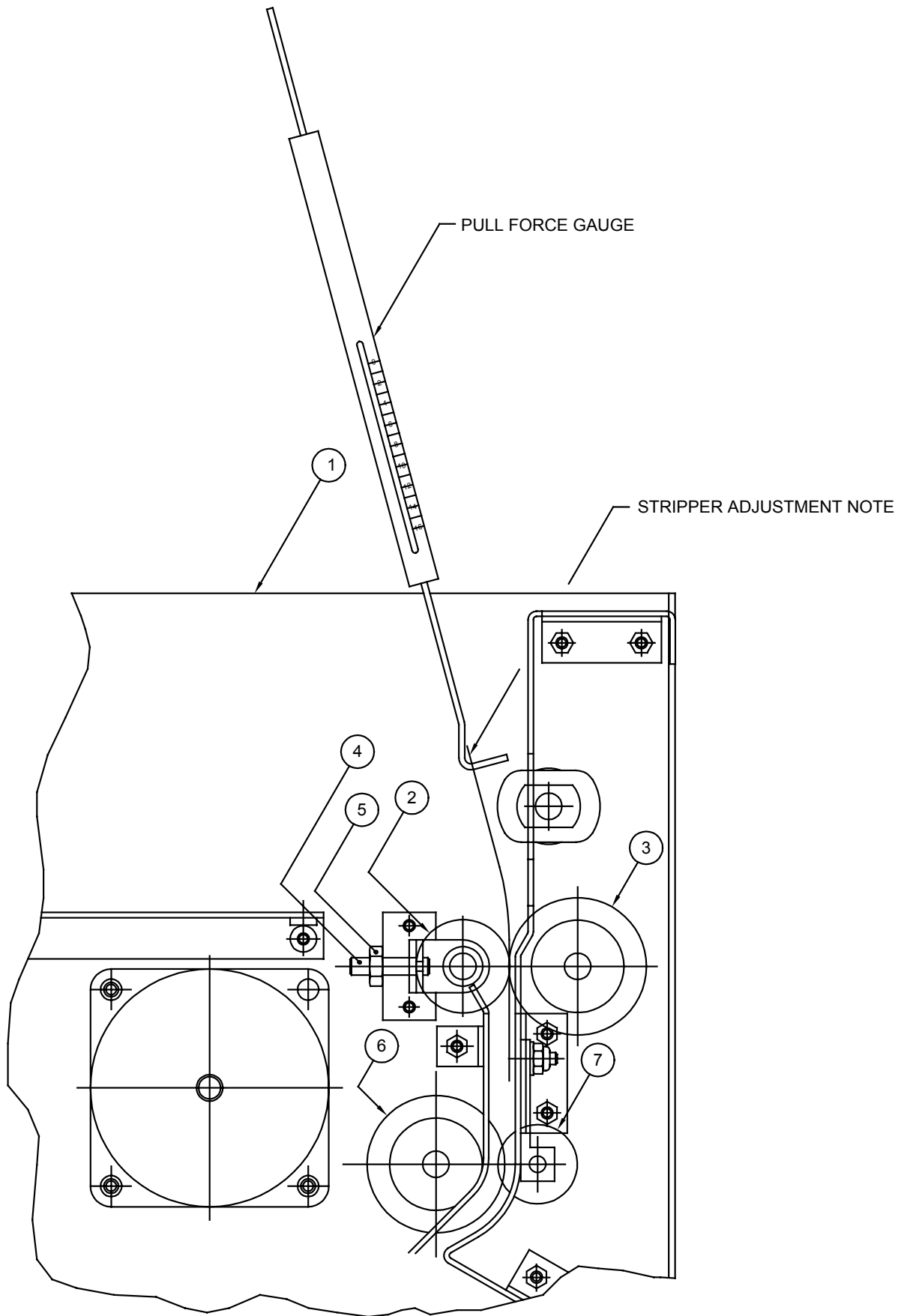
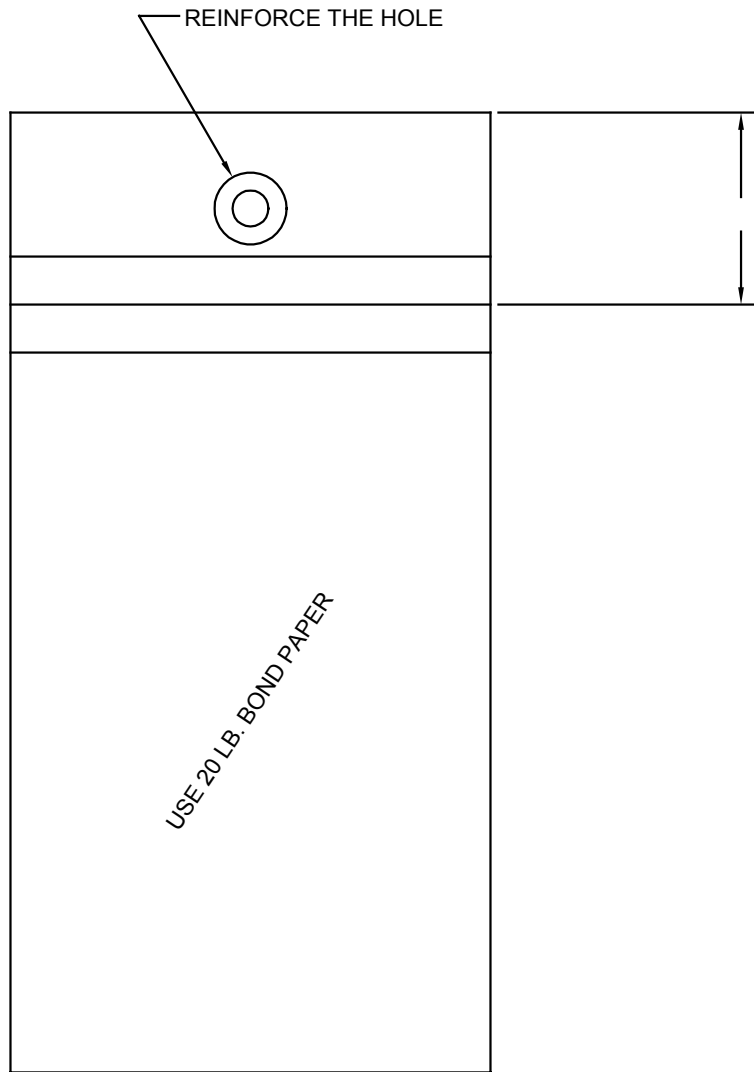

Figure 5 Stripper Friction Adjustment



Stripper Adjustment Note
(Actual Size)

ITEM	QUANTITY	DESCRIPTION	PART NUMBER
1	1	Right Side Plate	Reference
2	1	Stripper Shaft Assembly	61043
3	1	Feed Shaft Assembly	61045
4	1	Stripper Adjust Screw	52019
5	1	#8 -32 Hex Nut	40064
6	1	Transfer Shaft Assembly	61044
7	1	Idler Assembly	61012

IMPORTANT:

The procedure for adjusting the stripper is described in Section 5.8.I of this manual.

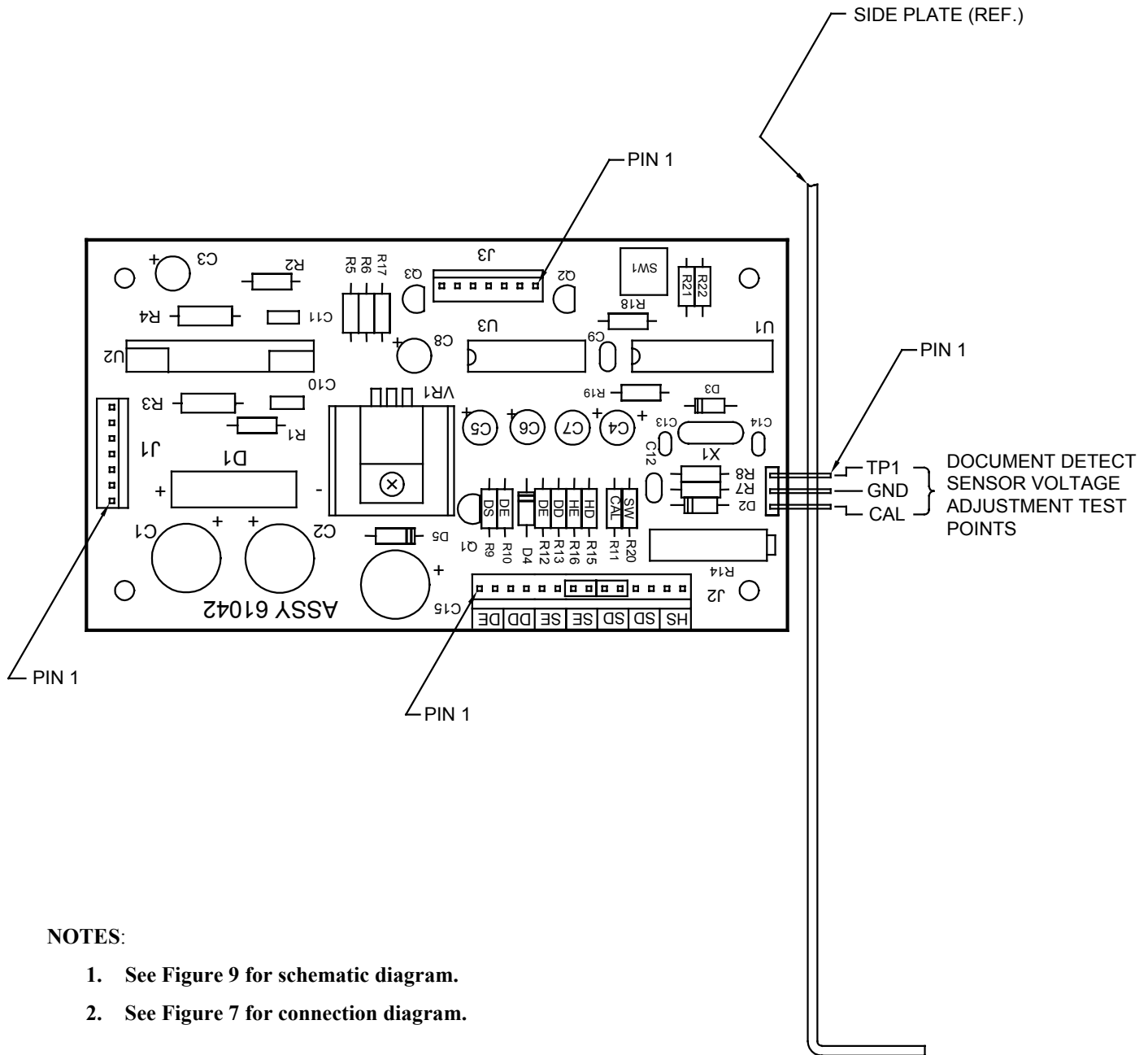

NOTES:

1. See Figure 9 for schematic diagram.
2. See Figure 7 for connection diagram.

**Figure 6 Logic/Power Board Assembly
(View from rear of unit)**

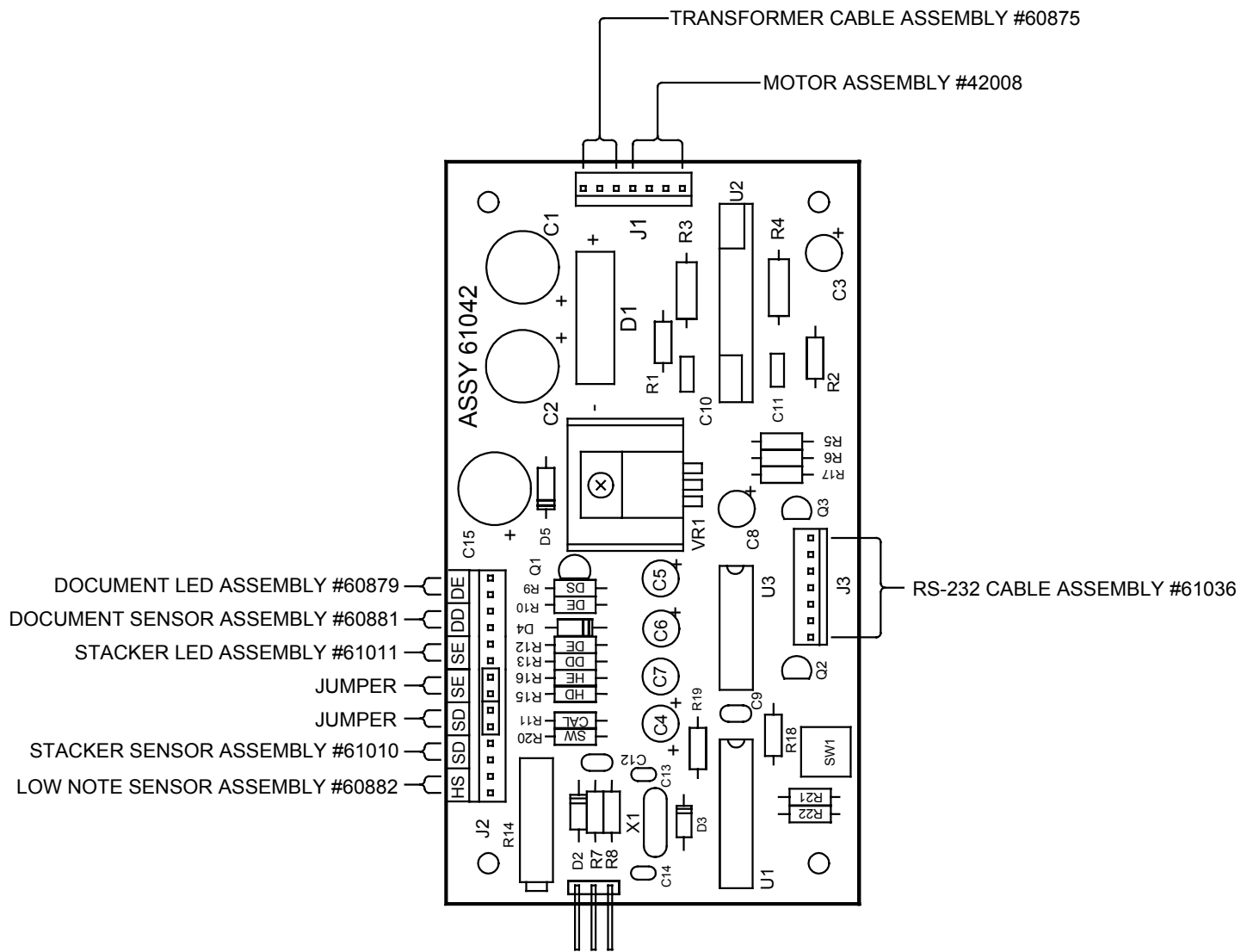

NOTE:

See Figure 9 for schematic diagram.

**Figure 7 Connection Diagram
(View from rear of unit)**

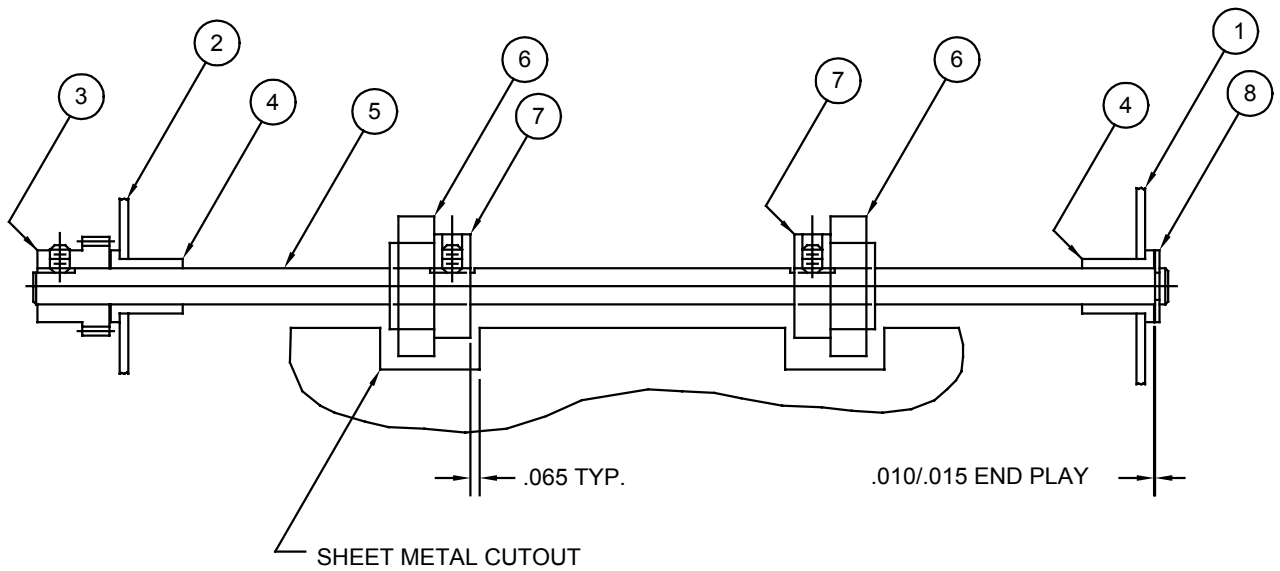

ITEM	QUANTITY	DESCRIPTION	PART NUMBER
1	1	Right Side Plate	Reference
2	1	Left Side Plate	Reference
3	1	Gear (20 Tooth)	42010
4	2	Bearing	50802
5	1	Picker Shaft	51804
6	2	Picker Tire	51825
7	2	Picker Hub	51478
8	1	E-Ring (.250 Dia.)	41256

Figure 10 Picker Shaft Assembly

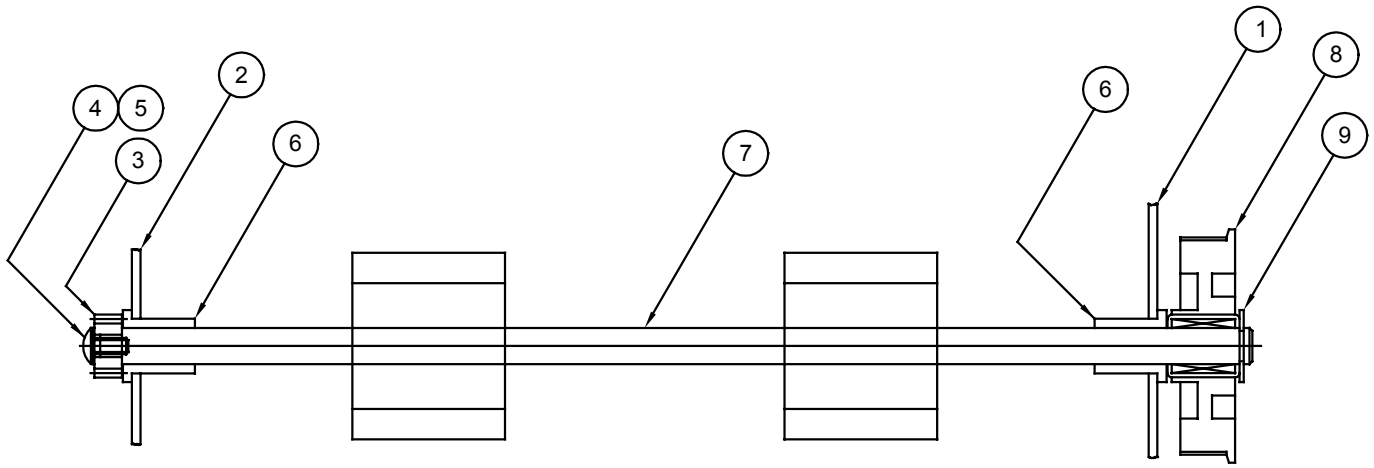

ITEM	QUANTITY	DESCRIPTION	PART NUMBER
1	1	Left side plate	Reference
2	1	Right side plate	Reference
3	1	Gear (12 tooth)	42104
4	1	#4-40 Screw (Truss Hd.)	40268
5	1	#4 Lock Washer (Ext. Tooth)	41754
6	2	Bearing	50802
7	1	Feed Shaft Assembly	61045
8	1	Timing Pulley Assembly (60 Tooth)	61046
9	1	E-Ring (.250 Dia.)	41256

Figure 11 Feed Shaft Assembly

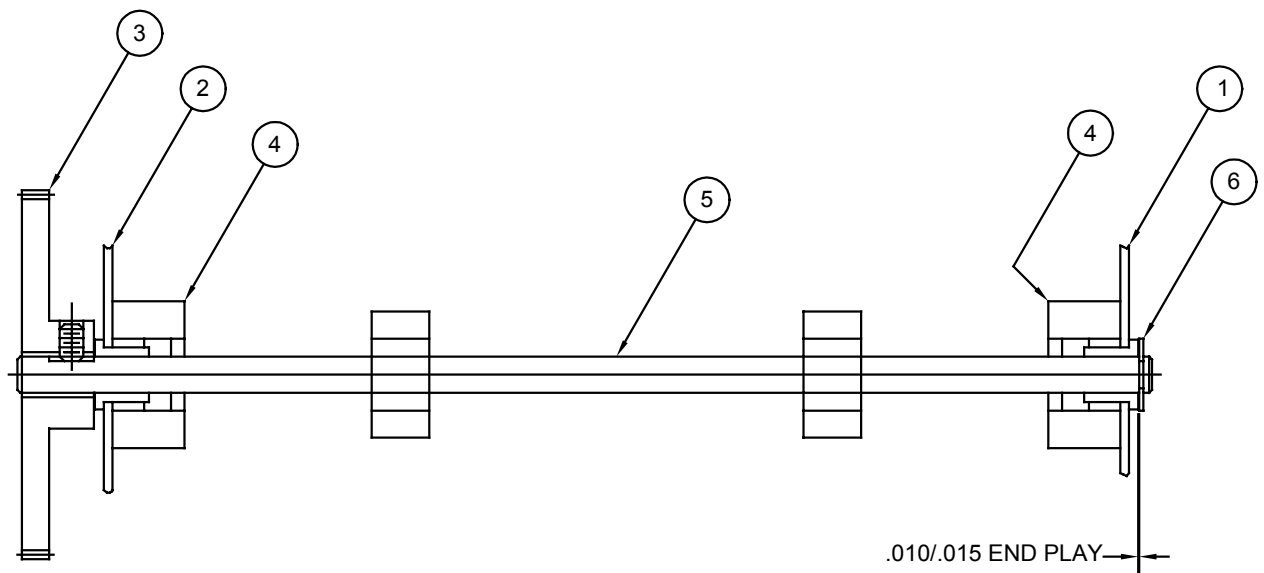

ITEM	QUANTITY	DESCRIPTION	PART NUMBER
1	1	Right side plate	Reference
2	1	Left side plate	Reference
3	1	Gear (80 tooth)	42011
4	2	Bearing block assembly	61009
5	1	Stripper shaft assembly	61043
6	1	E-ring (.250 dia.)	41256

Figure 12 Stripper Shaft Assembly

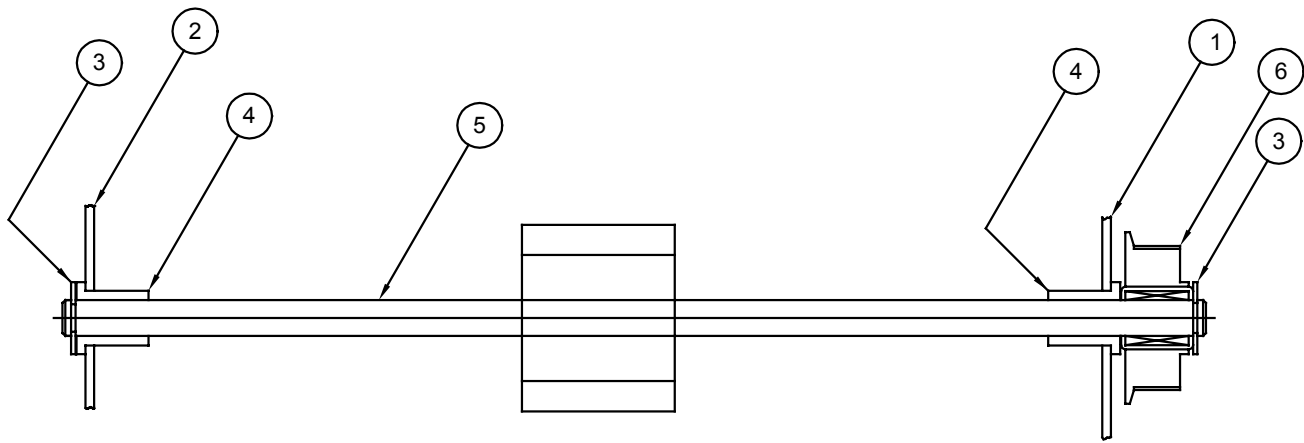

ITEM	QUANTITY	DESCRIPTION	PART NUMBER
1	1	Right Side Plate	Reference
2	1	Left Side Plate	Reference
3	2	E-Ring (.250 Dia.)	41256
4	2	Bearing	50802
5	1	Transfer Shaft Assembly	61044
6	1	Timing Pulley Assembly (40 Tooth)	61048

Figure 13 Transfer Shaft Assembly

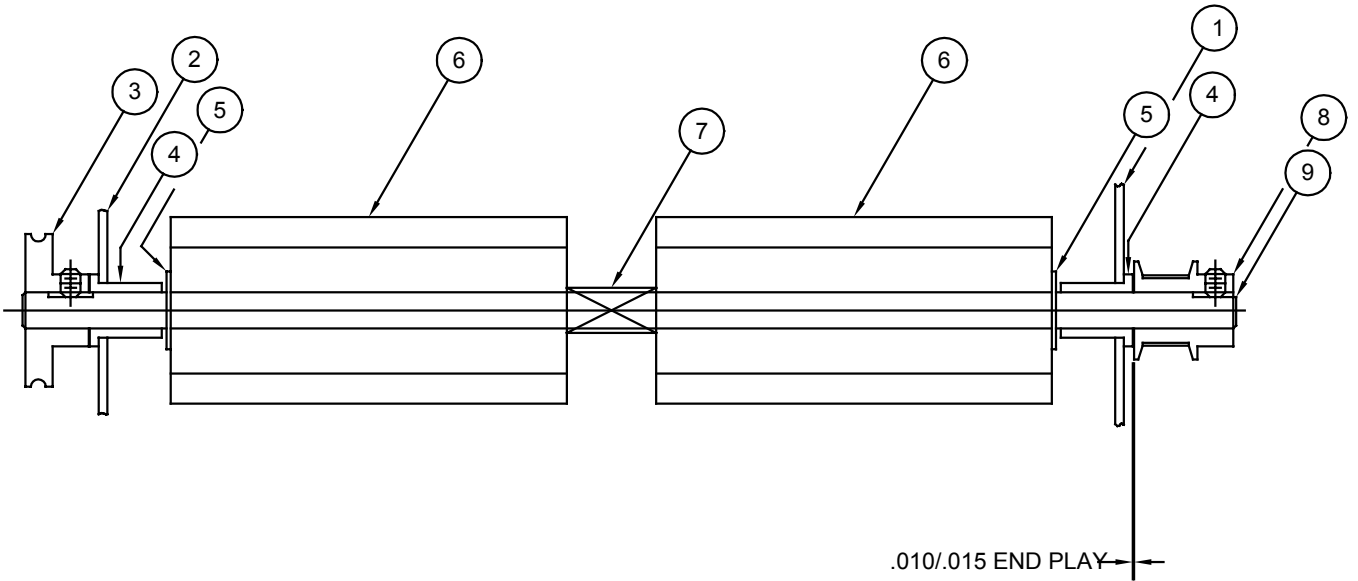

ITEM	QUANTITY	DESCRIPTION	PART NUMBER
1	1	Right Side Plate	Reference
2	1	Left Side Plate	Reference
3	1	O-Ring Pulley	51087
4	2	Bearing	50802
5	2	E-Ring (.250 Dia.)	41256
6	2	Front Conveyor Roller	52103
7	1	Spring	41255
8	1	Timing Pulley (20 Tooth)	41967
9	1	Front Conveyor Shaft	52065

Figure 14 Front Conveyor Shaft Assembly

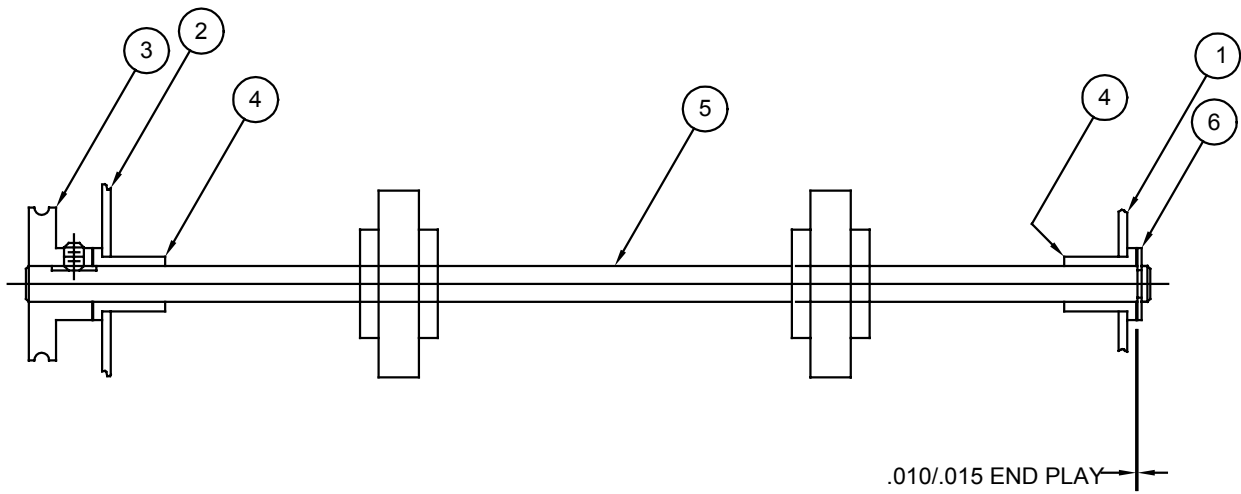

ITEM	QUANTITY	DESCRIPTION	PART NUMBER
1	1	Right Side Plate	Reference
2	1	Left Side Plate	Reference
3	1	O-Ring Pulley	51087
4	2	Bearing	50802
5	1	Rear Conveyor Shaft Assembly	61040
6	1	E-Ring (.250 Dia.)	41256

Figure 15 Rear Conveyor Shaft Assembly

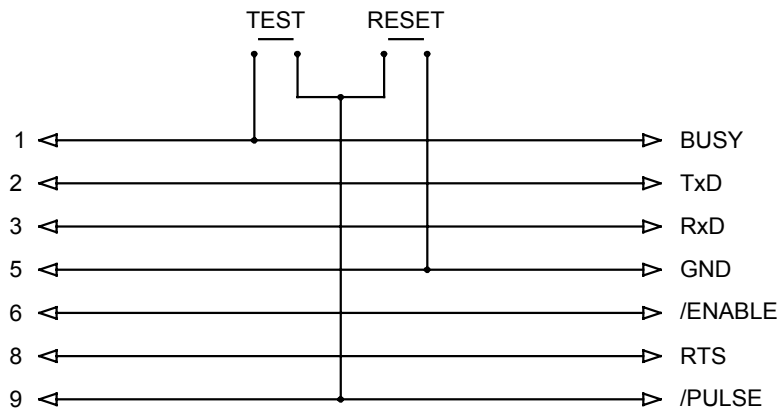

Single Note Test Circuit

Figure 16 Test Circuit

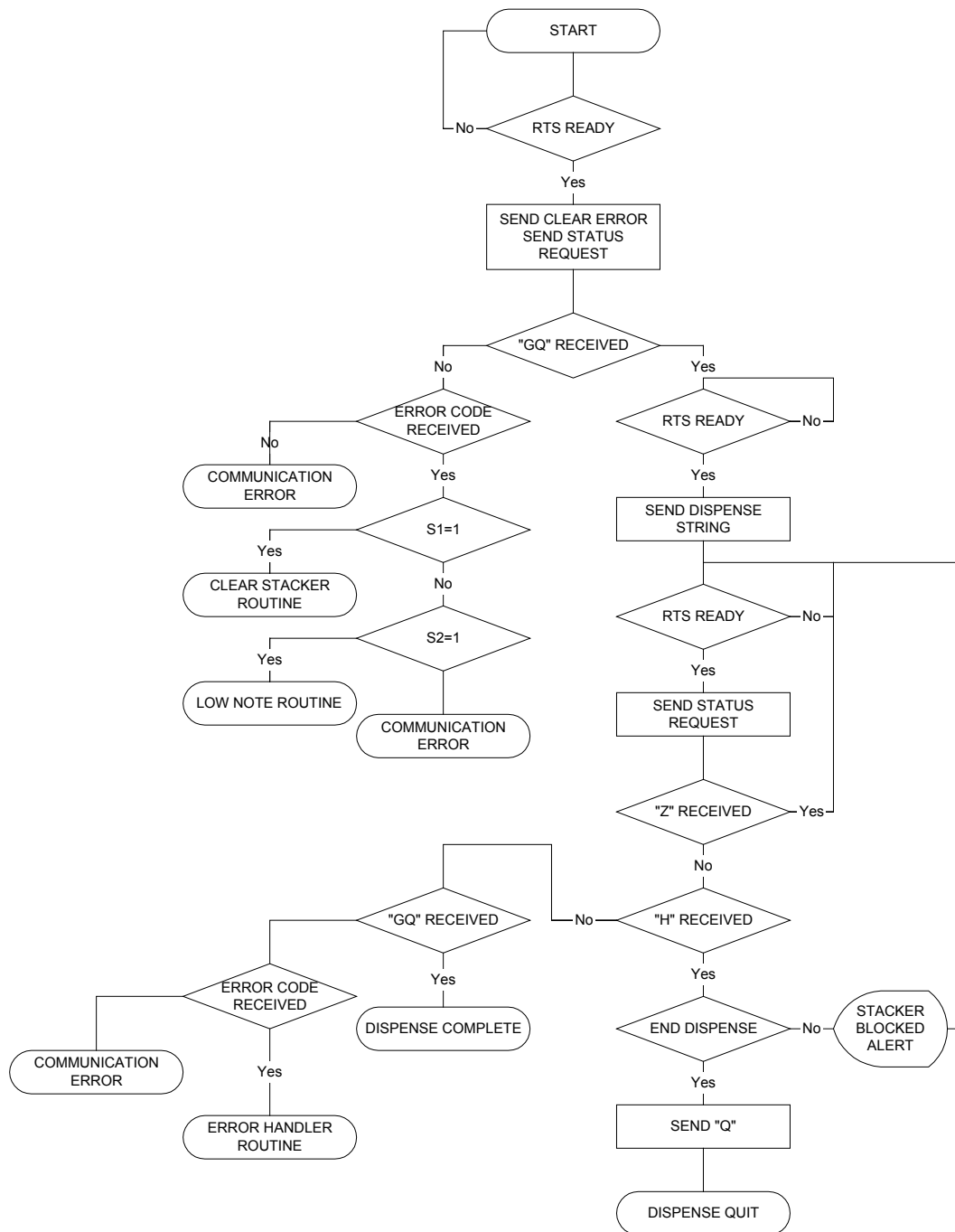
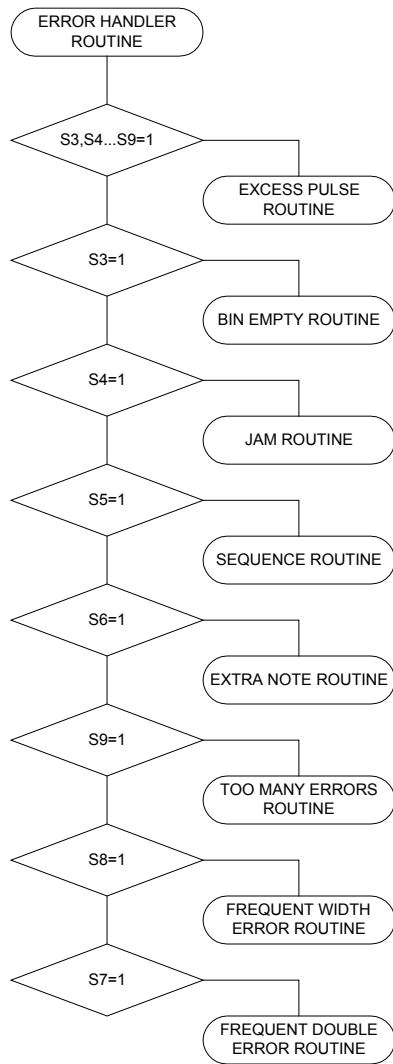

Figure 17 Sample RS-232 Command Sequence



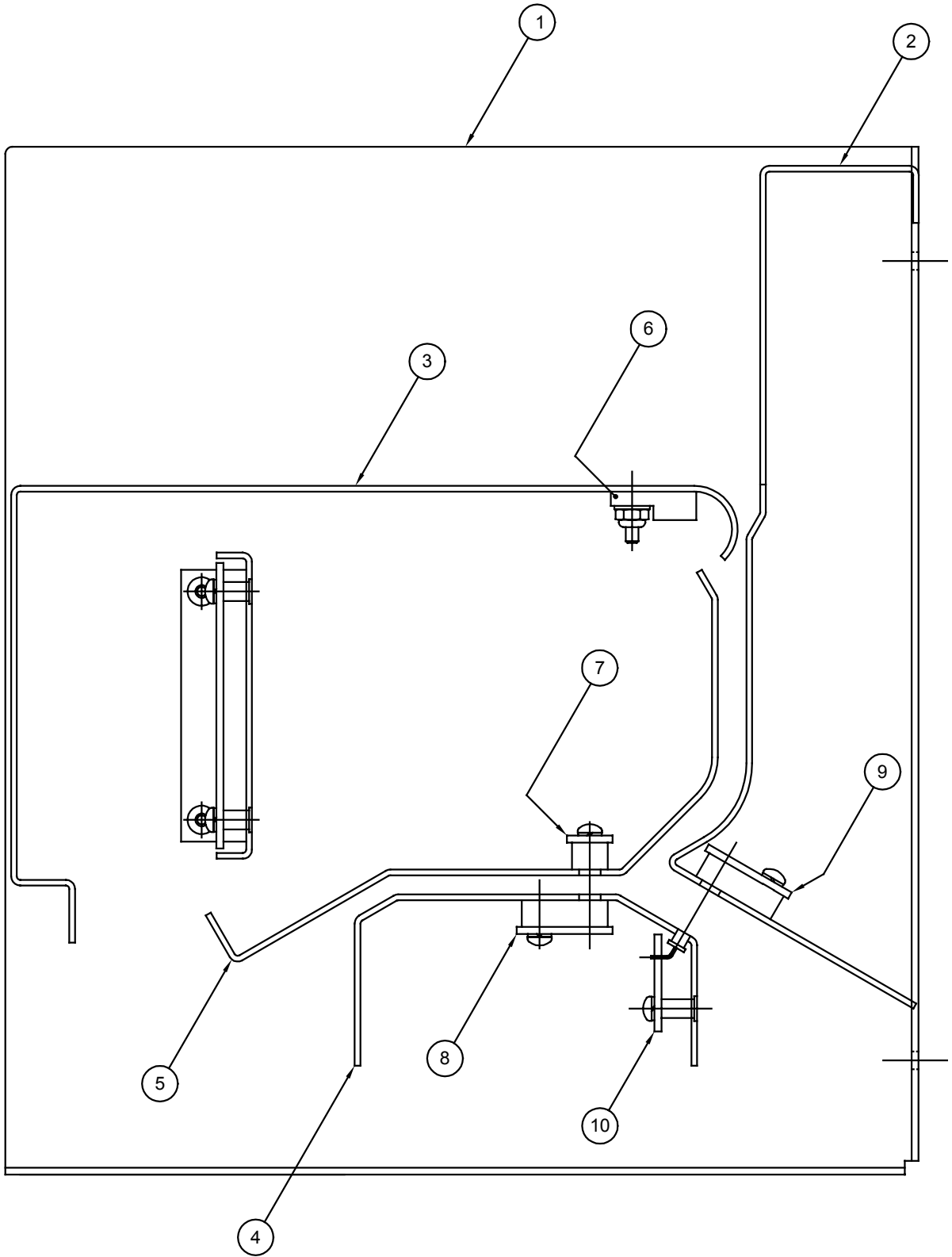

Figure 18 Sensor/LED Locations

ITEM	QUANTITY	DESCRIPTION	PART NUMBER
1	1	Right Side Plate	Reference
2	1	Feed Plate Assembly	Reference
3	1	Hopper Shelf Assembly	Reference
4	1	Stacker Plate Assembly	Reference
5	1	Conveyor Plate Assembly	Reference
6	1	Low Note Sensor Assembly	60882
7	1	Document Sensor Assembly	60881
8	1	Document LED Assembly	60879
9	1	Stacker Sensor Assembly	61010
10	1	Stacker LED Assembly	61011

